

I236 / I48I

BASIN MIXER WITH CLICK-UP WASTE &
THREE HOLE BIDET MIXER WITH SLOW RUNNING WASTE
INSTALLATION GUIDE

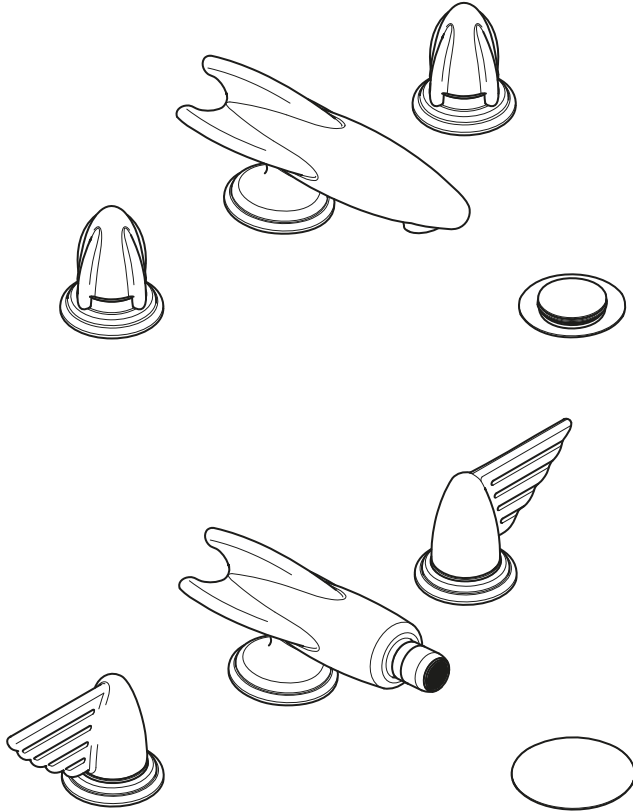

LEFROY BROOKS

DIMENSIONS

1236 model with levers

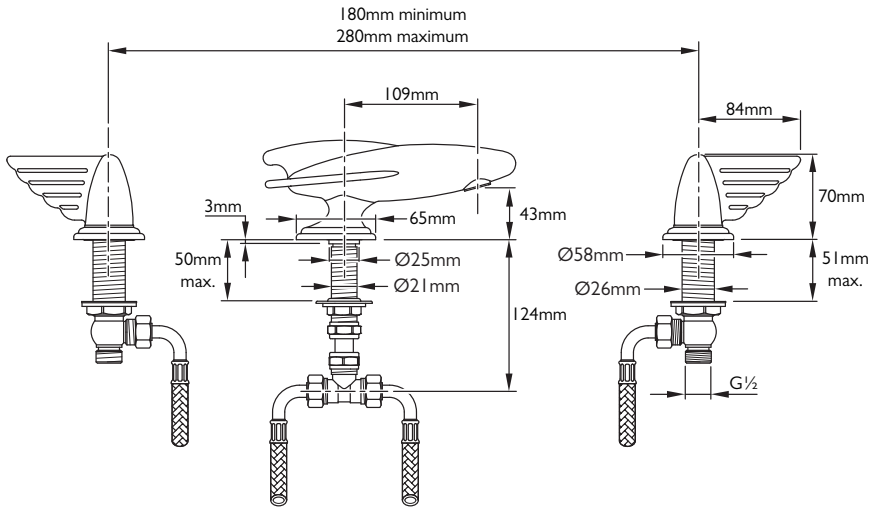

1481 model with handles

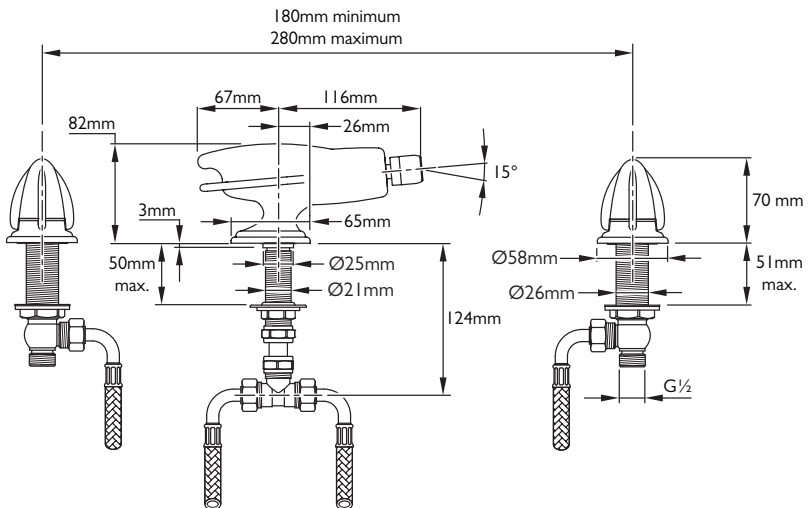

Not to scale

IMPORTANT INFORMATION

Professional installation

We recommend that our products are fitted by a fully qualified professional plumber. They should be installed correctly and in accordance with all local water regulations and the system protected by non-return valves (not supplied). All products should be accessible for routine servicing.

Suits all systems

This Lefroy Brooks product is potentially suitable for every possible application, type of boiler and water supply pressure. However, if your supply pressure is below 1 bar it is advisable to fit a water pump. For systems with combination boilers, it is not advisable to fit pumps (refer to boiler manufacturer).

Supply connections

The hot and cold water supplies should be connected using suitable ½" BSP connectors.

Supply temperature safety notice

To comply with local building regulations, current legislation, relevant standards and codes of practice a thermostatic mixing valve (TMV) should be fitted (not supplied) to the hot supply. This will restrict the temperature to a safe working maximum temperature. Maximum allowed temperatures vary subject to type of installation or specification of building.

Balancing flow

If there is a significant difference in water pressures between hot & cold supplies, we recommend an in-line flow suppressor/regulator (not supplied) be fitted. This should be fitted to whichever has the greater flow rate, in an accessible position close to the valve. Do not fit the flow suppressor/regulator at the spout as this will increase the pressure in the flexible hoses.

Water quality

In hard water areas, a suitable water treatment system should be provided to prevent limescale deposits (calcium deposits) which may effect the long term performance of the ceramic cartridges. Exterior surfaces should be gently wiped with a dry soft cloth after use to minimise water stains and limescale deposits.

Flushing system

It is most important to flush out all pipework thoroughly before connecting the product. Failure to do so is the single most common cause of ceramic cartridge failure.

Servicing

All serviceable parts are available to maintain your Lefroy Brooks product.

FLEXIBLE HOSE CONNECTIONS

It is recommended that the flow valves and hoses are installed as shown.

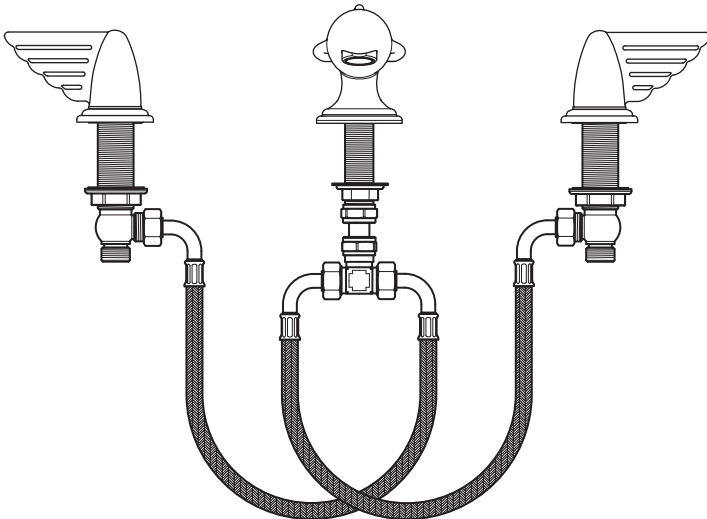
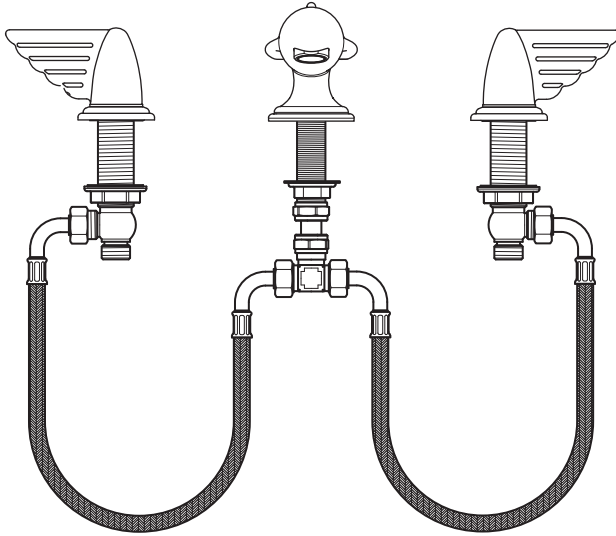

TYPICAL FLOW RATES

1236

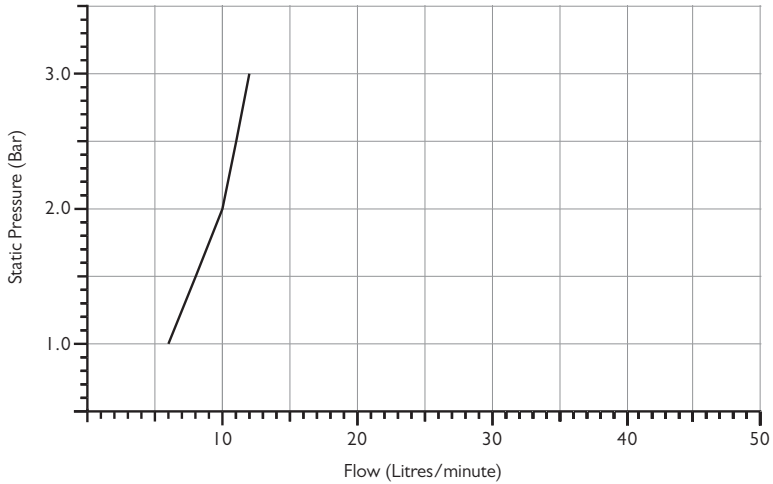

Note: Balanced pressures shown are applied directly to the hot and cold inlets; flow rates indicated are free flowing and may vary subject to restrictions created by installation, pipework, layout or application.

1481

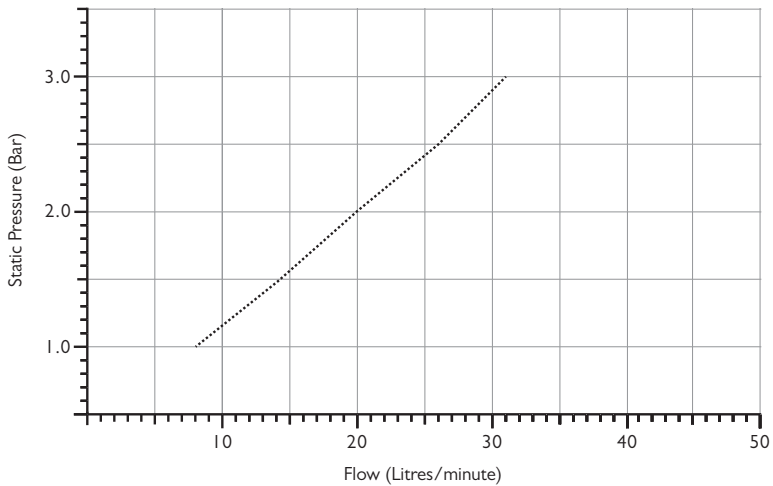

Note: Balanced pressures shown are applied directly to the hot and cold inlets; flow rates indicated are free flowing and may vary subject to restrictions created by installation, pipework, layout or application.

SPOUT INSTALLATION

Shown with I236 model. The same procedure applies to the I481 model.

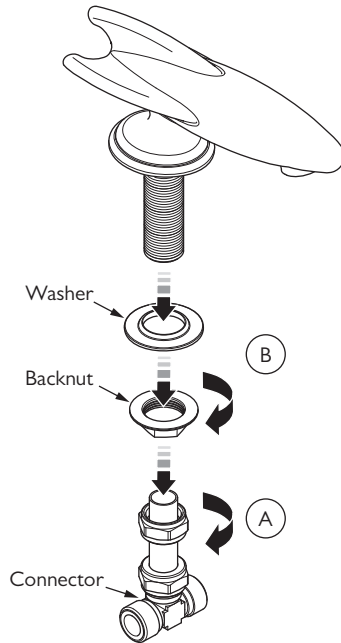

- 1 Where necessary drill a suitable sized hole in the mounting surface. We recommend $\text{Ø}27\text{mm} - \text{Ø}30\text{mm}$.
- 2 There is a short length of copper tube at the top of the connector. Unscrew the nut at the top of the copper tube (A). Gently pull the connector assembly clear of the threaded tail.
- 3 Unscrew and remove the backnut and washer from the threaded tail (B).

Shown with I236 model. The same procedure applies to the I481 model.

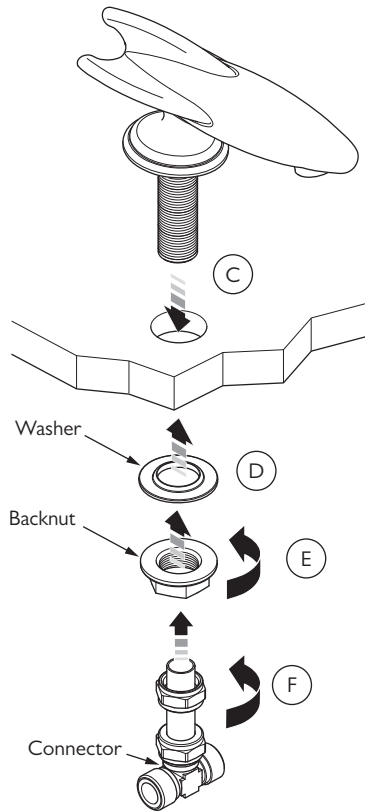

- 4 Pass the threaded tail of the spout through the hole in the mounting surface (C). Align the spout.
- 5 Locate the washer on to the threaded tail (D).

- 6 Screw the backnut on to the threaded tail and tighten to secure the spout (E).
- 7 Locate the connector and tighten the upper locking nut (F).

FLOW VALVE INSTALLATION

Shown with handle. The same procedure applies to lever models.

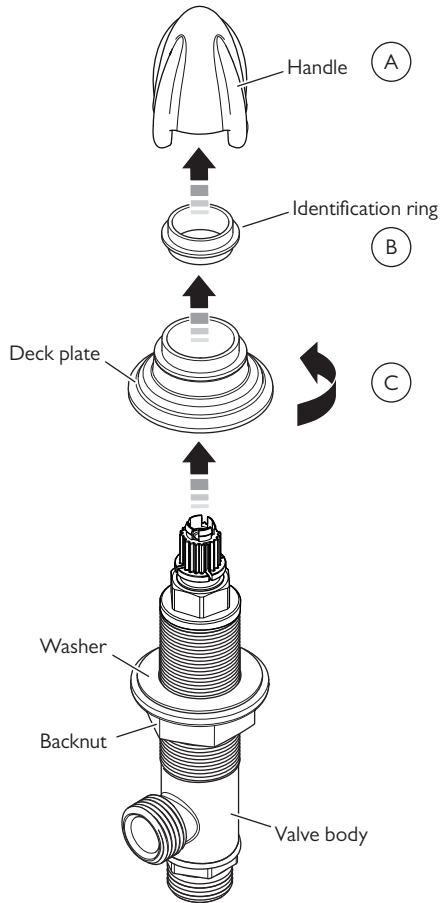

Before continuing please be aware that on lever models it is important to keep the flow valve bodies and lever assemblies together as supplied. Do not swap the lever assemblies from hot and cold valves.

I Where necessary drill $\text{Ø}28\text{--}30\text{mm}$ holes in the mounting surface.

- 2 Support the flow valve body then grasp the handle/lever and pull firmly in a straight line clear of the valve (A).
- 3 Lift the identification ring from the top of the deck plate (B).
- 4 Unscrew and remove the deck plate (C). Do not remove the backnut and washer.

Shown with handle. The same procedure applies to lever models.

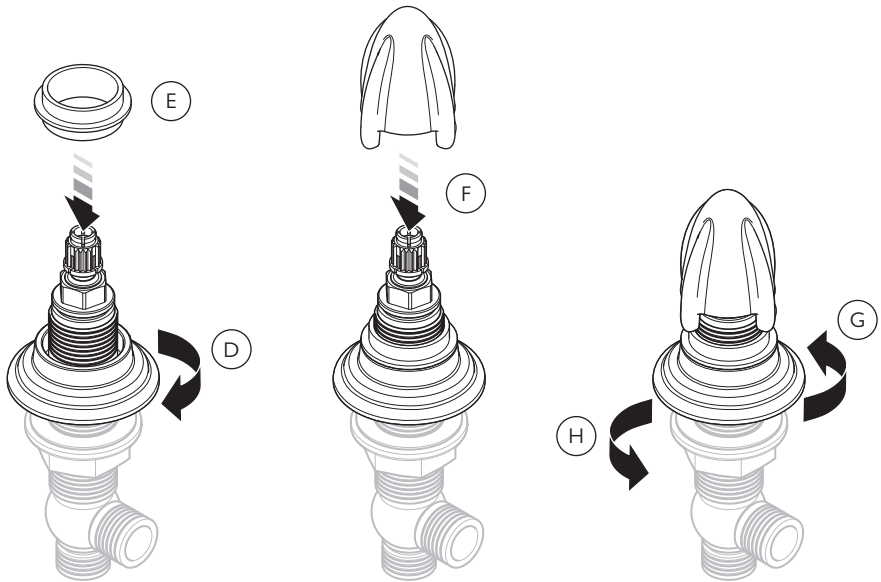

- 5 Locate the flow valve through the hole in the mounting surface.
- 6 Screw the deck plate on to the top of the flow valve, beyond the level of the ceramic cartridge (D).
- 7 On handle models rotate the splines on top of the ceramic cartridges so that they are in the fully clockwise position. On lever models rotate the splines on top of the 'hot' ceramic cartridge so that they are in the fully clockwise position and the splines on top of the 'cold' ceramic cartridge so that they are in the fully counter clockwise position. The handles/ levers can be loosely located to achieve this.
- 8 Rotate the flow valve body so that the side outlet port is facing the required direction for connection.
- 9 Locate the identification ring on to the top of the deck plate (E).
- 10 With the handle/lever aligned, locate the handle/lever assembly on to the splines of the cartridge adapter (F). Rotate the deck plate until the identification ring sits beneath the handle/lever leaving no gap between them (G).
- 11 Ensure that the handle/lever alignment is as required before securing the flow valve in place. The flow valve can be rotated to correct any small alignment issues. Tighten the backnut to secure the flow valve in place (H).
- 12 Connect the flexible hoses.
- 13 Connect the flow valves to the water supplies.
- 14 Turn on the water supplies and check for leaks.
- 15 Check the operation of the flow valves.

SERVICING – CARTRIDGE REPLACEMENT

Shown with handle. The same procedure applies to lever models.

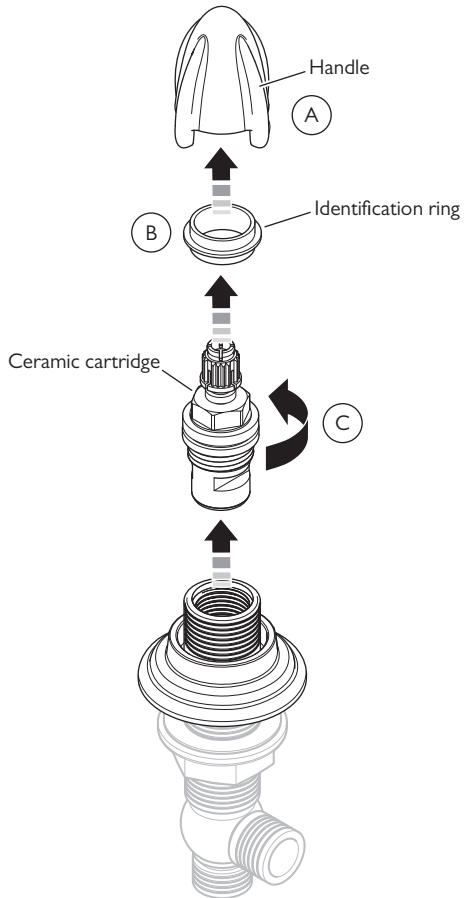

Before continuing please ensure that the water supplies have been isolated and drained where necessary.

- 1 To remove, grasp the handle(s)/lever(s) and pull firmly in a straight line clear of the valve (A).
- 2 Lift and remove the identification ring (B).
- 3 Using a 17mm a/f spanner or socket unscrew the cartridge and remove (C).
- 4 Check inside the valve body for any debris or limescale. Wipe clean as required.
- 5 Screw a new ceramic cartridge into the valve body and tighten using a 17mm spanner or socket.
- 6 Open the water supply.
- 7 Check for leaks.
- 8 Replace the handle(s)/lever(s). Gently align the handle on the spindle then push to locate.
- 9 Check operation of the cartridge.

SERVICING – CLEANING THE SPOUT/BIDET AERATOR

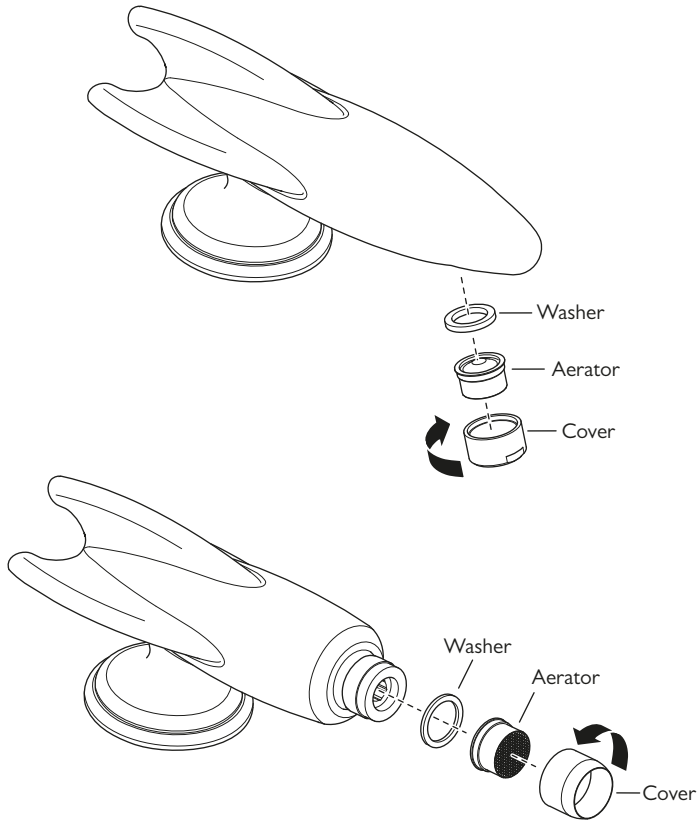

1 There is an aerator located in the end of the spout/bidet. To remove this unscrew and remove the cover.

2 The aerator can be cleaned in warm soapy water or replaced.

3 Assemble in the reverse order.

FAULT FINDING

The hot/cold flow valves are turned off but the spout/bidet drips continuously.

- Replace the ceramic cartridge(s) in the flow valves. See 'Replacement parts' section for spare part numbers and the 'servicing – cartridge replacement' section.

Water flow from the spout is reduced.

- Debris from the water supply may be causing restriction at the aerator located in the end of the spout. The aerator can be removed for cleaning (see 'servicing – cleaning the spout aerator' section).
- Check that there are no tight bends in the flexible hoses.

Noisy operation

- Check that there are no tight bends in the flexible hoses.
- Reduce water pressure.

Leaks from underside of basin

- Flexible hose joints not tight.
- Nuts on connector not tight.

REPLACEMENT PARTS

- PDV021 – Pair of ½" x ½ turn ceramic cartridges with spline adapters for handle models (RH).
- PDV024 – Pair of ½" x ¼ turn ceramic cartridges with spline adapters for lever models (RL).
- PSP031 – Pair of sealing 'O' rings for flow valve deck plates.
- PSH022 – Pair of braided hoses.
- PSH031 – Aerator, washer & housing for 1236 model.
- PSH028 – Aerator, washer & housing for 1481 model.



CONTRACT ENQUIRIES

+44 (0)1992 708 316

info@lefroybrooks.co.uk

CUSTOMER SERVICE, SPARES & TECHNICAL ENQUIRIES

+44 (0)1902 390 894

technical@lefroybrooks.co.uk

LEFROYBROOKS.CO.UK

Whilst every effort is made to ensure the accuracy of these, they are subject to change without notice as part of the company's product development process. The use of trademarks, product design and artwork is subject to licence or agreement with LBIP Ltd. The design registrations, trademark registrations and copyrights are protected by law and the use or reproduction outside the terms of an agreement is prohibited. The right to modify designs and dimensions is reserved. LBIP Ltd is a member of ACID (Anti Copying in Design). E&OE