

TH 1198 / TL 1198
MONO BIDET MIXER
INSTALLATION GUIDE

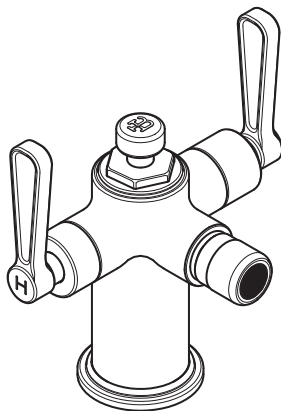

LEFROY BROOKS

DIMENSIONS

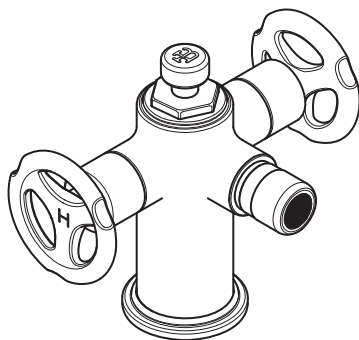
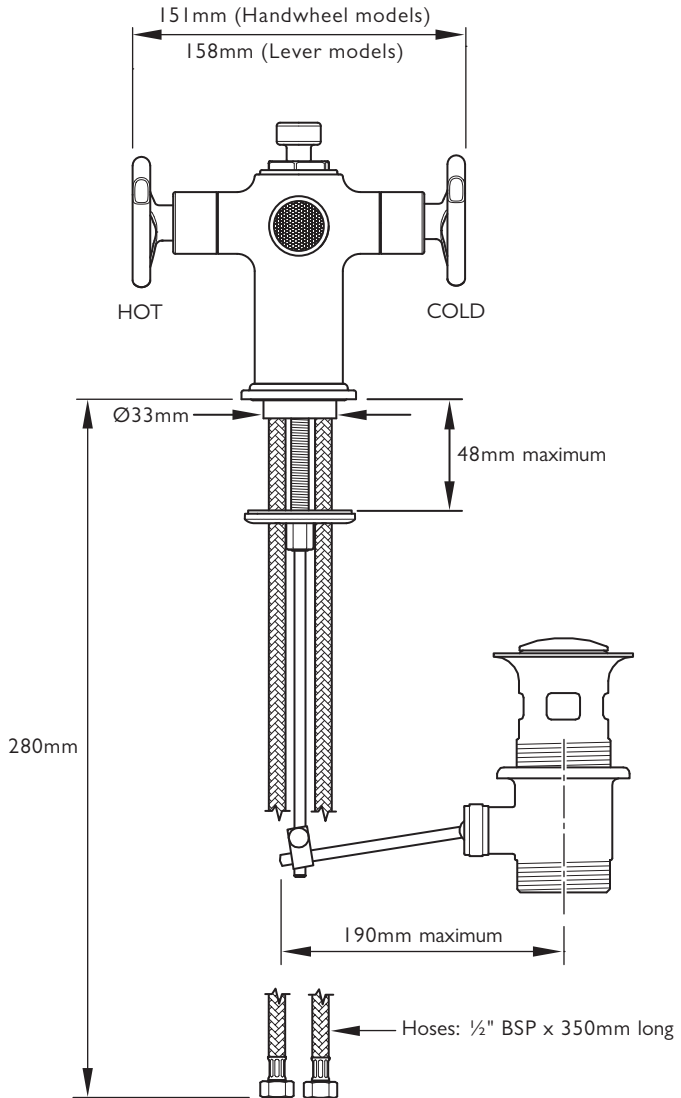

Not to scale

DIMENSIONS

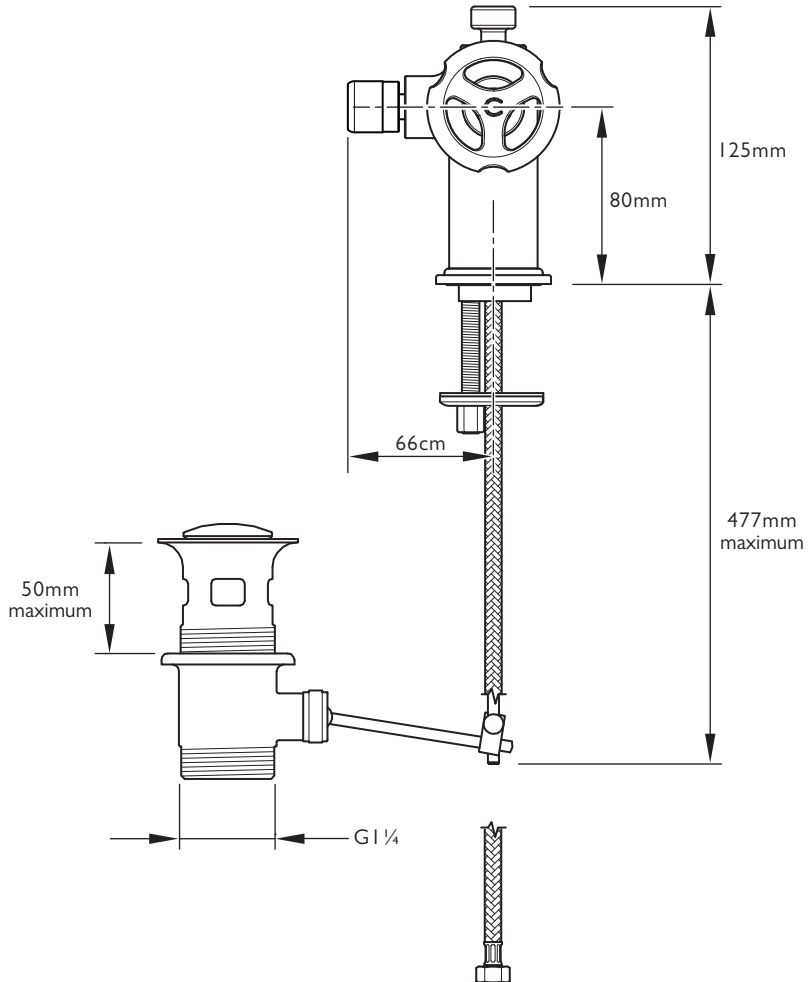

Not to scale

TYPICAL FLOW RATES

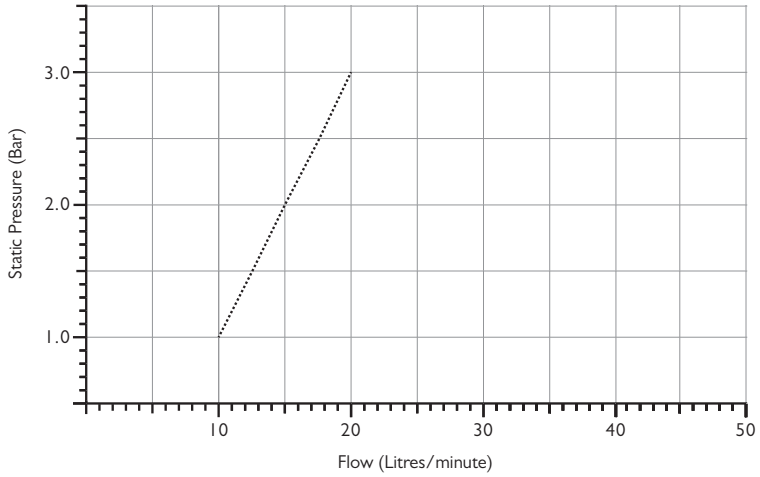

Note: Balanced pressures shown are applied directly to the hot and cold inlets; flow rates indicated are free flowing and may vary subject to restrictions created by installation, pipework, layout or application.

IMPORTANT INFORMATION

Professional installation

We recommend that our products are fitted by a fully qualified professional plumber. They should be installed correctly and in accordance with all local water regulations and the system protected by non-return valves (not supplied). All products should be accessible for routine servicing.

Suits all systems

This Lefroy Brooks product is potentially suitable for every possible application, type of boiler and water supply pressure. However, if your supply pressure is below 1 bar it is advisable to fit a water pump. For systems with combination boilers, it is not advisable to fit pumps (refer to boiler manufacturer).

Supply connections

The hot and cold water supplies should be connected using suitable ½" connectors.

Supply temperature safety notice

To comply with local building regulations, current legislation, relevant standards and codes of practice a thermostatic mixing valve (TMV) should be fitted (not supplied) to the hot supply. This will restrict the temperature to a safe working maximum temperature. Maximum allowed temperatures vary subject to type of installation or specification of building.

Balancing flow

If there is a significant difference in water pressures between hot & cold supplies, we recommend an in-line flow suppressor/regulator (not supplied) be fitted. This should be fitted to whichever has the greater flow rate.

Water quality

In hard water areas, a suitable water treatment system should be provided to prevent limescale deposits (calcium deposits) which may effect the long term performance of the ceramic cartridges. Exterior surfaces should be gently wiped with a dry soft cloth after use to minimise water stains and limescale deposits.

Flushing system

It is most important to flush out all pipework thoroughly before connecting the product. Failure to do so is the single most common cause of ceramic cartridge failure.

Servicing

All serviceable parts are available to maintain your Lefroy Brooks product.

PARTS IDENTIFICATION

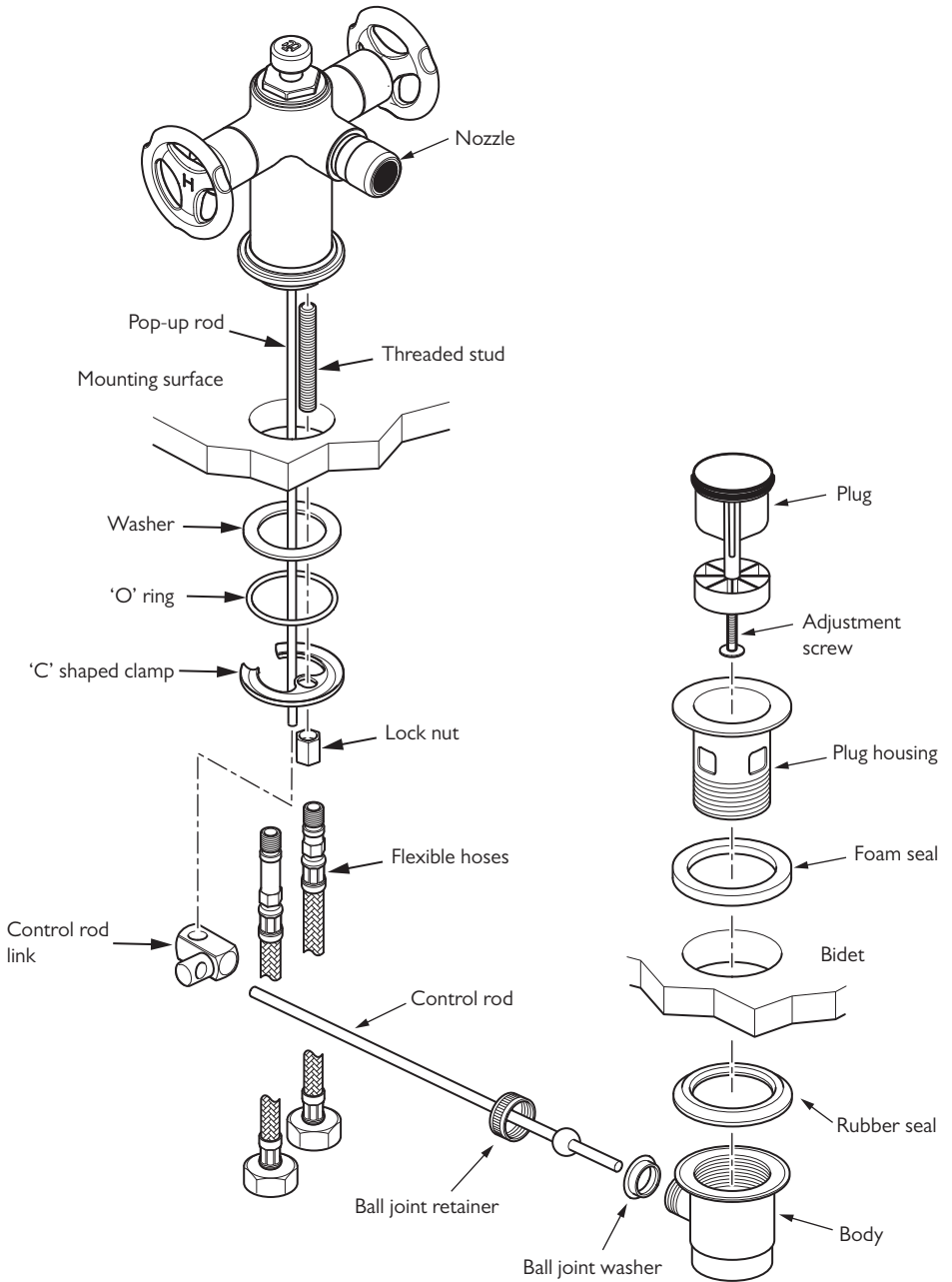

BIDET MIXER INSTALLATION

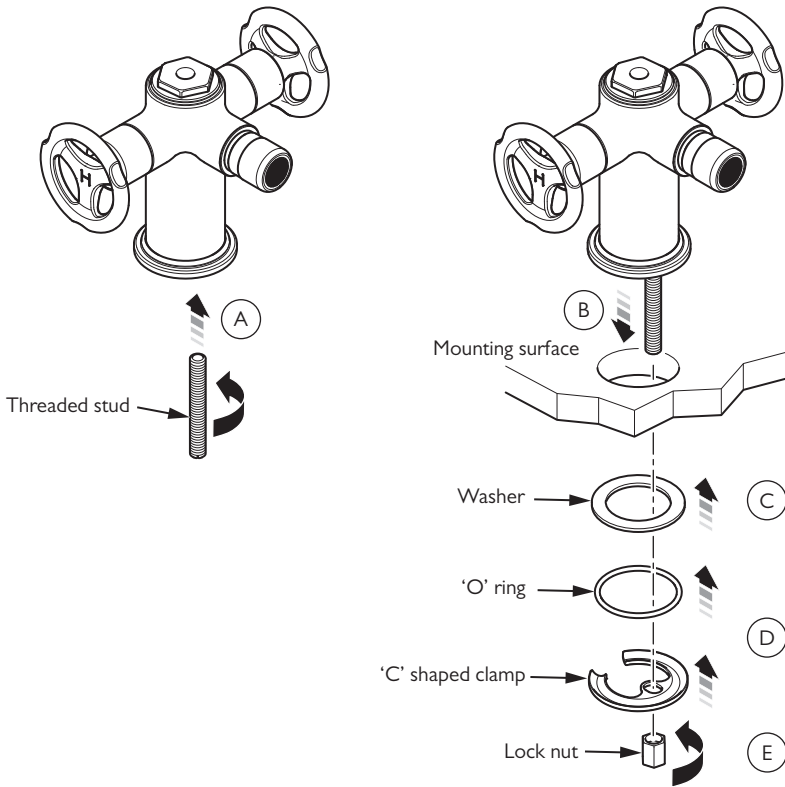

- 1 Where required, drill a $\text{Ø}34\text{--}38\text{mm}$ hole in the mounting surface.
- 2 One end of the threaded stud has a flat bladed screwdriver slot. Using a flat bladed screw driver, screw the threaded stud into the threaded hole in the underside of the bidet mixer (A).
- 3 Place the bidet mixer through the hole in the mounting surface (B).
- 4 Locate the washer over the threaded stud (C).
- 5 Locate the 'O' ring into the recess in the 'C' shaped clamp then locate the clamp onto the threaded stud (D).
- 6 Screw the lock nut onto the threaded stud and tighten to secure the bidet mixer in place (E).

POP-UP WASTE INSTALLATION

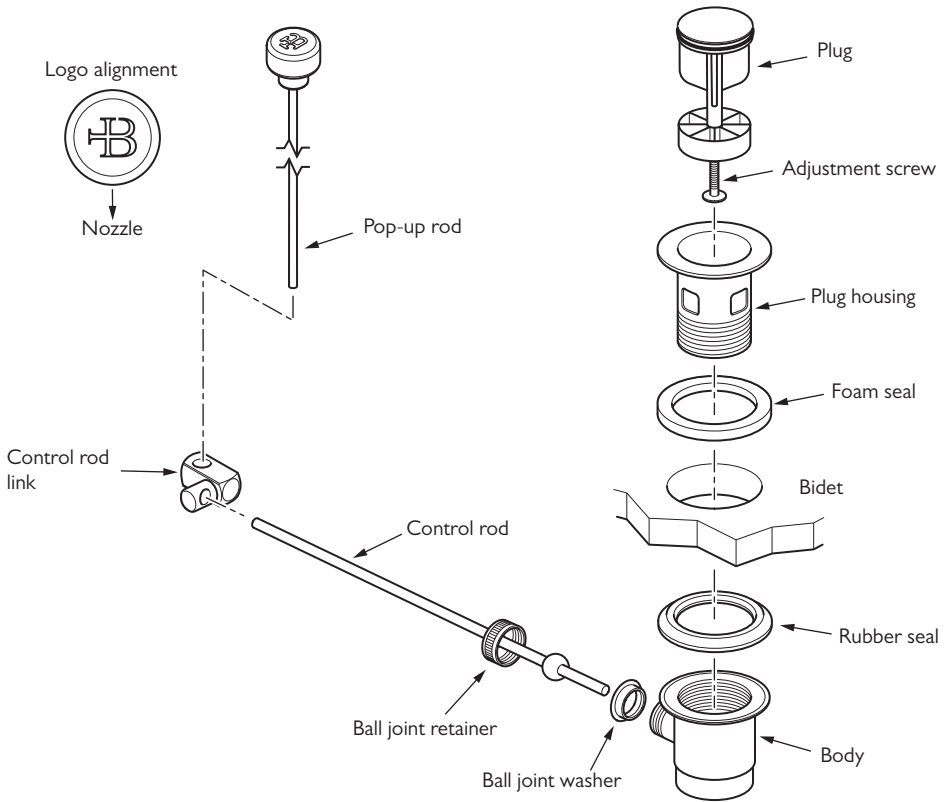

- 1 Insert the pop-up rod into the hole in the top of the bidet mixer.
- 2 Assemble the pop-up waste to the bidet with the foam seal on top of the mounting surface and the rubber seal below. The wide diameter of the rubber seal sits on top of the waste body. Tighten by hand.
- 3 Gently clamp the control rod link to the pop-up rod. Test the operation of the pop-up waste and if satisfactory fully tighten the control rod link to the pop-up rod. If not satisfactory then make adjustments to the control rod link as required. If the operation is stiff simply loosen the ball joint retainer as required.
- 4 Connect the flexible hoses to the bidet mixer. There is a hexagonal recess in the end of the each hose. If required, insert a 6mm hexagonal key to tighten the hose in place.
- 5 After flushing the pipework connect the hot and cold water supplies to the bottom of the appropriate flexible hoses.
- 6 Pressure test the installation to ensure that all joints are tight and do not leak, especially where pipework will be concealed.

SERVICING – CARTRIDGE REPLACEMENT

Shown with handwheels. The same procedure applies to lever models.

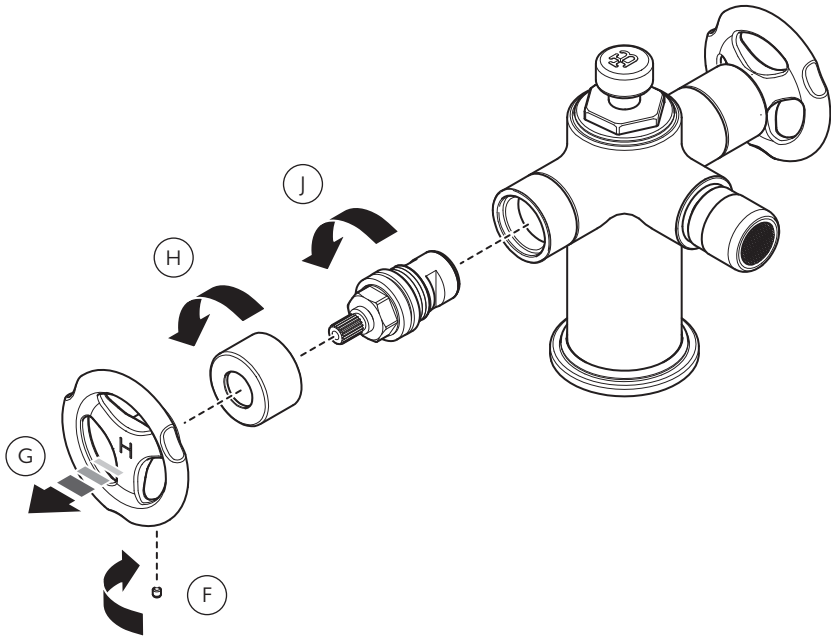

Before continuing please ensure that the water supplies have been isolated and drained where necessary.

- 1 To remove the ceramic cartridge(s), unscrew the set screw(s) in the underside of the handwheel(s)/lever(s) (F) using a 2mm hexagonal key.
- 2 Pull the handwheel(s)/lever(s) to remove (G).
- 3 Unscrew and remove the shroud(s) (H). We recommend this is done by hand as tools may damage the decorative surface. To aid grip we recommend wearing rubber gloves such as those used for washing up.
- 4 Unscrew and remove the ceramic cartridge(s) using a 17mm spanner (J).
- 5 Assemble in the reverse order.

SERVICING – CLEANING THE NOZZLE AERATOR

Shown with handwheels. The same procedure applies to lever models.

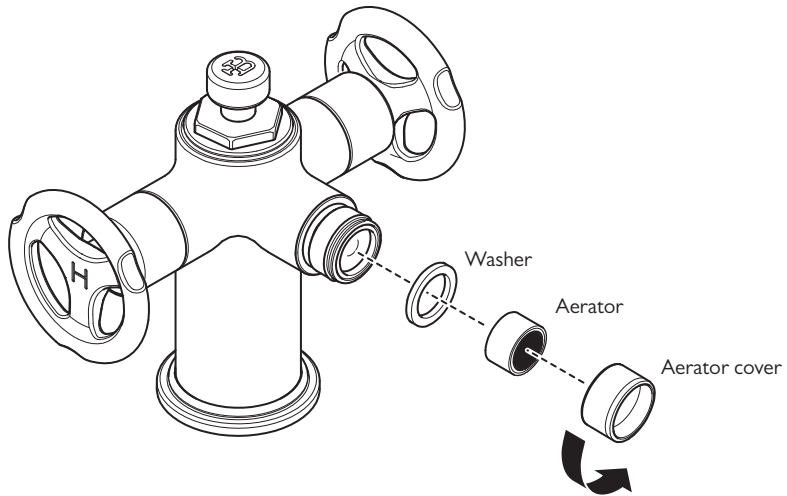

1 There is an aerator located in the end of the nozzle. To remove the aerator unscrew and remove the aerator cover.

2 The aerator can be cleaned in warm soapy water or replaced.

3 Assemble in the reverse order.

FAULT FINDING

The hot/cold flow valves are turned off but the nozzle drips continuously.

- Replace the ceramic cartridge(s). See below for spare part numbers and the 'servicing – cartridge replacement' section.

Water flow from the nozzle is reduced.

- Debris from the water supply may be causing restriction at the aerator located in the end of the nozzle. The aerator can be removed for cleaning (see 'servicing – cleaning the nozzle aerator' section).
- Check that there are no tight bends in the flexible hoses.

Noisy operation

- Check that there are no tight bends in the flexible hoses.
- Reduce water pressure.

Leaks from underside of bidet

- Flexible hose joints not tight.

Pop-up rod movement is stiff/loose

- Adjust the ball joint retainer where the horizontal control rod fits into the waste assembly (see 'parts identification' or 'pop-up waste installation' section).

REPLACEMENT PARTS

Both handwheel and lever models use ¼ turn ceramic cartridges.

PHL035 – Pair of ½" x ¼ turn ceramic cartridges (one counter clockwise closing (left side) and one clockwise closing (right side)).

PHL040 – Single ½" x ¼ turn ceramic cartridge (clockwise closing – right side).

PHL041 – Single ½" x ¼ turn ceramic cartridge (counter clockwise closing – left side).

PSH095 – Pair of braided flexible hoses.

PFR022 – Aerator and aerator washer

PSH028 – Aerator sleeve



CONTRACT ENQUIRIES

+44 (0)1992 708 316

info@lefroybrooks.co.uk

CUSTOMER SERVICE, SPARES & TECHNICAL ENQUIRIES

+44 (0)1902 390 894

technical@lefroybrooks.co.uk

LEFROYBROOKS.CO.UK

Whilst every effort is made to ensure the accuracy of these, they are subject to change without notice as part of the company's product development process. The use of trademarks, product design and artwork is subject to licence or agreement with LBIP Ltd. The design registrations, trademark registrations and copyrights are protected by law and the use or reproduction outside the terms of an agreement is prohibited. The right to modify designs and dimensions is reserved. LBIP Ltd is a member of ACID (Anti Copying in Design). E&OE